

Aquaterra

ver. 2017

by **CGS plus**

Channel and river engineering design software



Professional software solutions for Civil Engineering

Channel and river engineering design software

Aquaterra is a professional 3D CAD software for channel and river engineering design. It integrates MIKE FLOOD or HEC-RAS hydraulic calculations with flood protection design, torrent and landslide control, and irrigation systems design. Based on layout, profile, and cross-sections, it creates 3D solid channel and river bed models, supports QTO data export, and offers plan production tools. Carefully designed UI and workflows are consistent with the engineering practices. This makes Aquaterra surprisingly fast-to-learn and easy-to-use.

Fields of use

- River channel design,
- Flood protection design,
- Torrents and landslides control,
- River restoration,
- Irrigation systems design,
- Dam reservoirs design,
- Wetland protection ,
- Culvert section design,
- Earthworks:
quarries, open mine pits,
dump areas, earth barriers, etc.,
- Rehabilitation of landslides.



Aquaterra

by **CGS plus**

Some Aquaterra references:

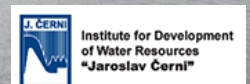

Aquaterra is ready for quick and effortless integration into BIM processes and workflows.

Create 3D solid channel and river bed models, attach extended material data, and seamlessly transfer project data to AutoCAD Civil 3D, Autodesk InRoads, or Autodesk Navisworks. Aquaterra channel and river bed model is ready for IFC data integration.



Design features

Digital terrain modeling

The Surface creation tool is included in CGS plus software to produce detailed Digital Terrain Model (DTM) based on various surveys or other input data: total station data files, points, break lines, blocks, etc. This offers the possibility to use Aquaterra on plain AutoCAD or BricsCAD.

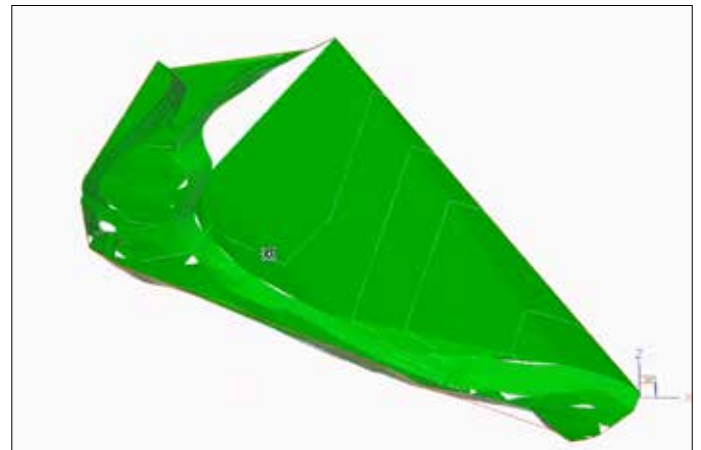

River alignment design tools

Aquaterra provides a wide range of advanced alignment, profile geometry design, and editing tools. They include P(V)I design, floating and fixed elements design, alignment design created from the existing polyline, or ultimately creating a best-fit alignment based on existing channel or river bed survey data. A number of alignment labels, reports and data export options give you the flexibility to cover a wide range of user requirements.

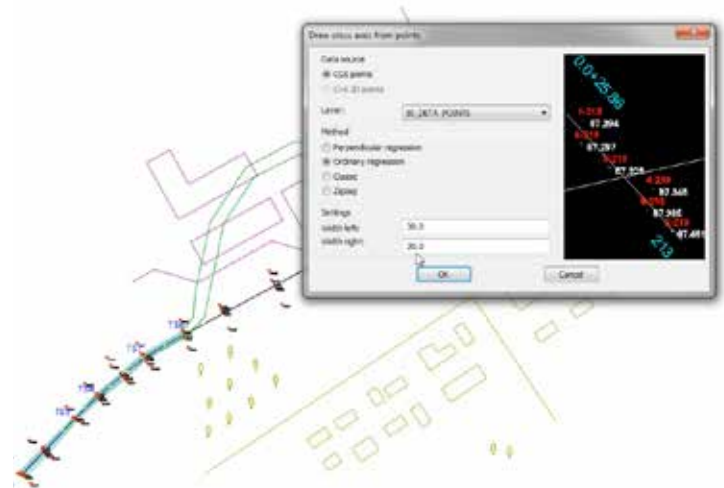

Water level representation and smart lines definition

Water level lines represent data obtained from hydraulic calculation software (MIKE FLOOD or HEC-RAS). They are displayed relative to the specific alignment in the drawing. To present side objects like channels, dykes, property limits, etc., you can define smart lines in the layout and project them to profile and/or cross section views. The Smart lines functionality is connected with the point's projection, which offers similar projection options, but dedicated to point objects along any alignment.

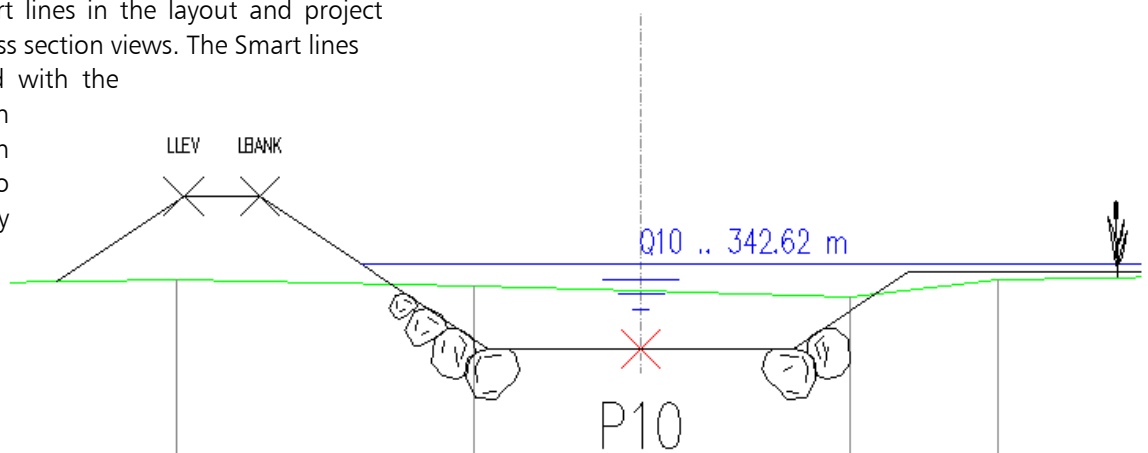

CGS plus software licensing and purchase options

CGS software can be purchased as perpetual license, with or without subscription or it can be rented for various time periods. Single and network licenses are available. CGS plus also offers a very attractive CGS plus financing option (PAY1/USE5) which allows instant use of sufficient number of licenses, payment in monthly rates at a longer time-period, thus significantly increasing the value of your investment.



Cross sections design and editing capabilities

Enter 1D, 2D water levels or combined calculations and design new or edit existing channel and river bed cross sections geometry. Add dykes and other objects using the large set of tools available. Recalculate water levels and check geometry changes impact for accurate project evaluation.

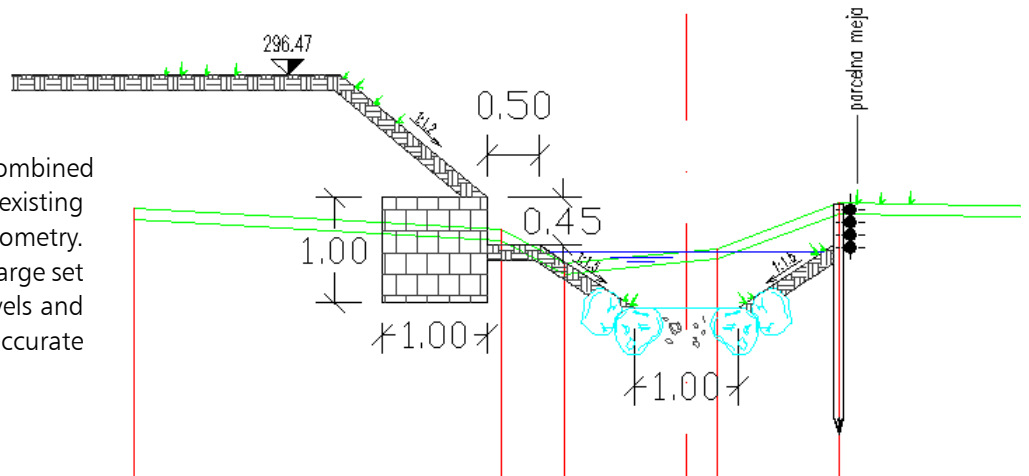

Quantity take-off (QTO)

Aquaterra calculates material quantity take-off and features a QTO data export tool with custom defined Pay Item (Bill of materials) options. It gives users the possibility to link material defined in the drawing with a material database in cost estimate software, thus supporting digital data transfer and fast cost recalculation when project changes arise.

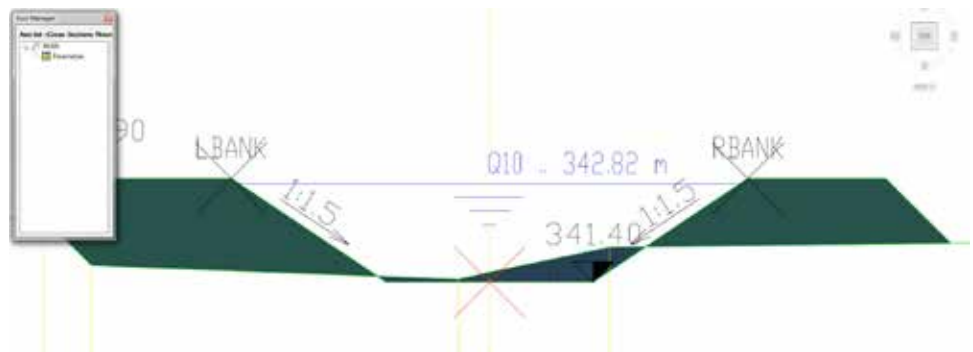

River groins

Groins are a rigid hydraulic structures built from a bank in rivers that interrupt water flow and limit the movement of sediment. Aquaterra supports design of groins along selected banks as 2D elements with varying gradient values.

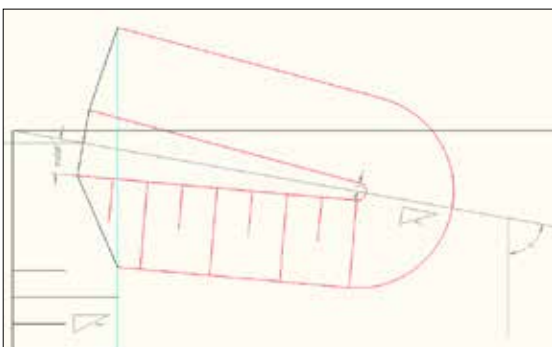

Select Aquaterra package that meets your needs!

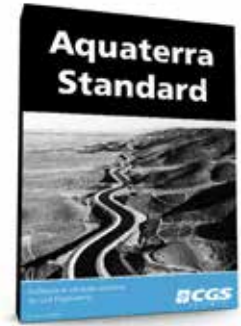
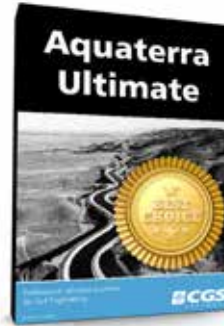

Survey data import	+	+
Digital terrain modeling tool (DTM)	+	+
3D Grading	+	+
Alignment design	+	+
Profile design	+	+
Cross sections design	+	+
3D River modeling	+	+
Points/Lines projection to profile/cross sections	+	+
Labeling and dimensioning tools	+	+
Quantity Take-off	+	+
Riverbanks design	+	+
Water level display	+	+
Export to Google Earth	+	+
HEC-RAS hydraulic interface	+	+
DHI / MIKE FLOOD hydraulic interface	+	X
Support for BIM (Support for 3D Solid objects, LandXML data import/export, IFC ready)	+	X

3D Surface and 3D Solid Model

Channel and river bed 3D model can be created as 3D surface or 3D solid model. 3D surface model can be generated automatically from 3D channel or river bed cross sections definition and terrain model, or it can be built with the grading function. 3D solid model is created on the basis of cross-section areas, with materials and volumes defined as extended data. All solid models, including extended data, can be imported into Autodesk Inroadworks, Navisworks and can be used in various BIM workflows.

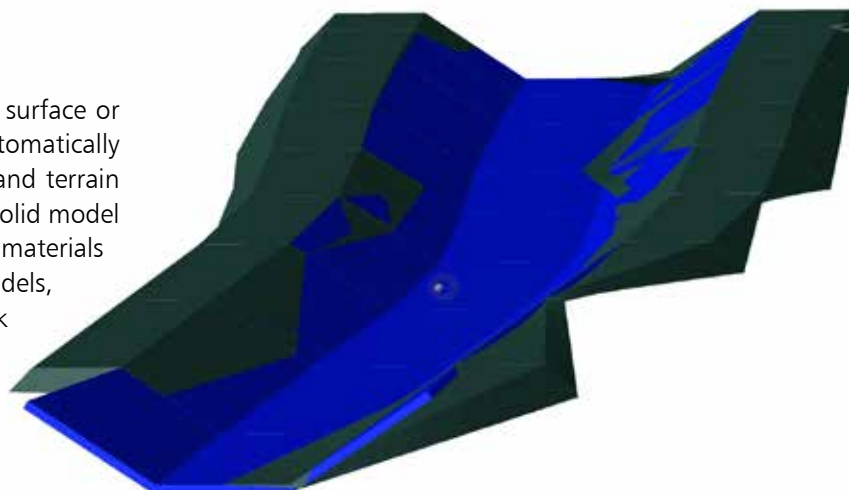

Interfaces

Graphical data exchange with MIKE FLOOD

MIKE FLOOD by DHI is an advanced professional flood modeling solution that enables simulation of any flood problem. It can involve rivers, floodplains, flooding in streets, drainage networks, coastal areas, dams, levee and dike breaches, or any combination of these.

Aquaterra's integrated MIKE FLOOD interface transfers graphical data into MIKE FLOOD where water flow calculations are made. These results are transferred back into Aquaterra where water levels can be displayed in profile and cross section.

MIKE FLOOD 2D results (floodplain lines) export to Aquaterra is also supported for drawing production within the CAD environment.

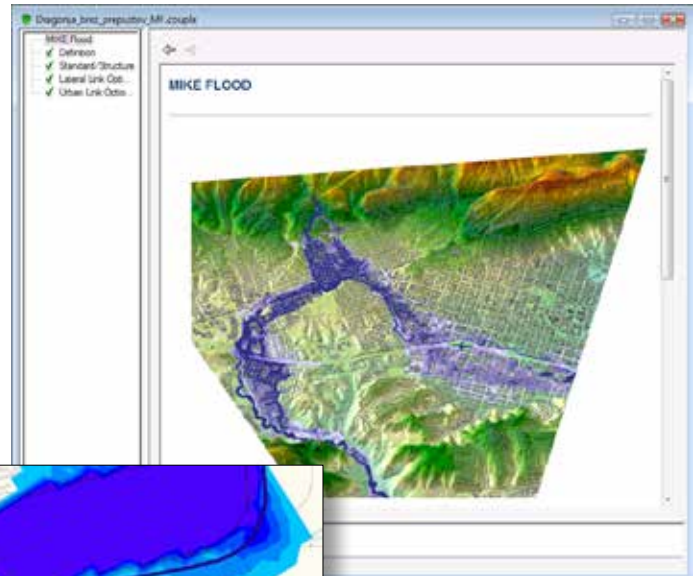

Graphical data exchange with HEC-RAS

HEC-RAS is an established software for one-dimensional steady flow and two-dimensional unsteady flow hydraulic calculations.

Aquaterra's integrated HEC-RAS interface enables the transfer of channel or river geometry from a CAD environment into HEC-RAS where water flow calculations are made. Calculation results can be transferred back into Aquaterra where calculated water levels are displayed in profile and cross sections. Taking into account the results, engineers can now modify existing channel or river topography, using Aquaterra's advanced cross-section design and editing tools.

Through Aquaterra's interface, geometry can also be imported directly from HEC-RAS, edited in Aquaterra and sent back to HEC-RAS for further analysis.

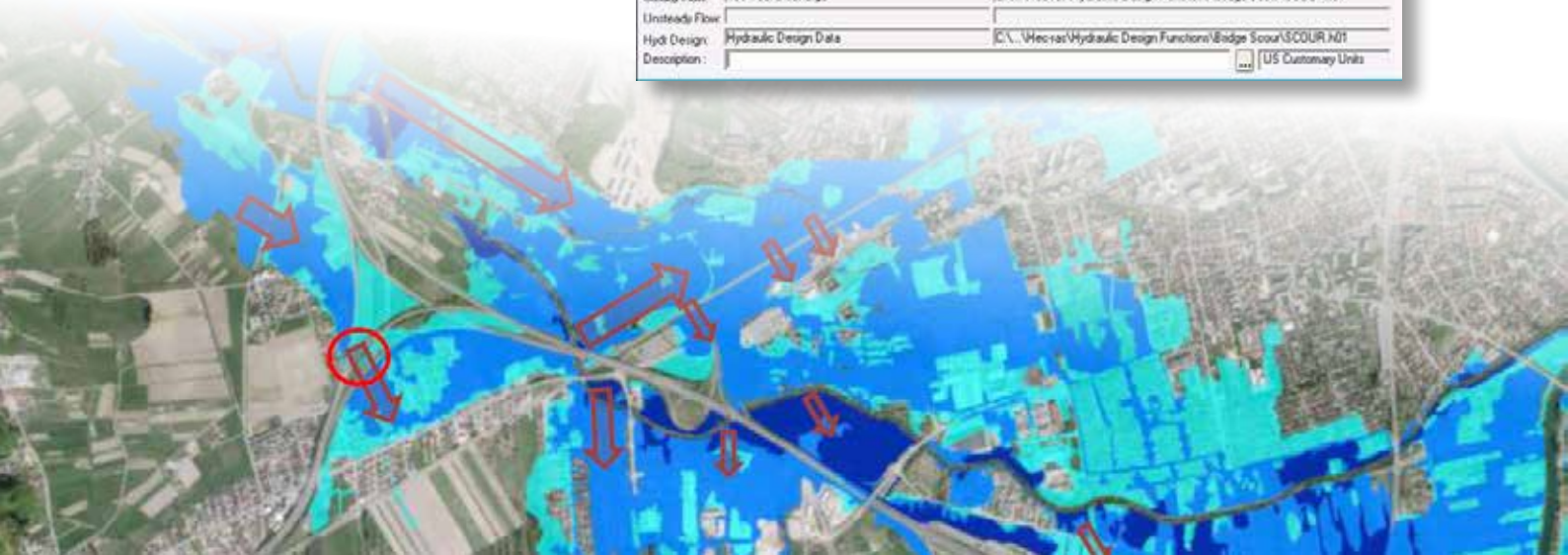
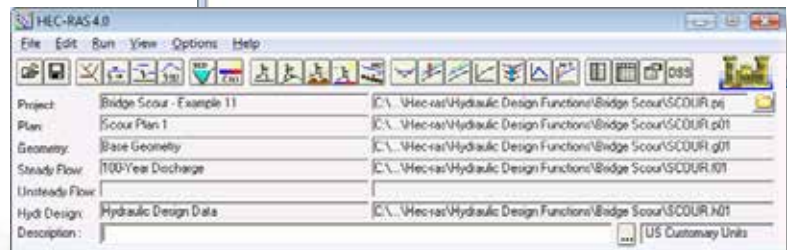
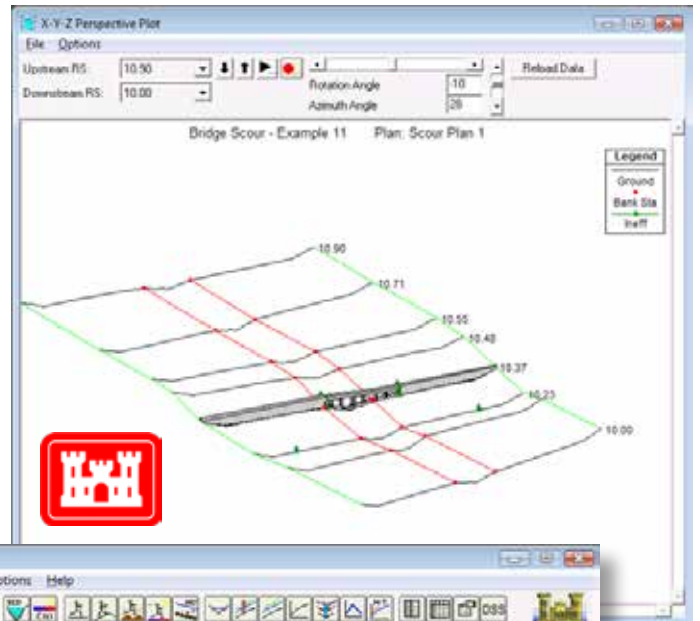

General features

Dynamic Data Model

Aquaterra stores all design data inside a .dwg data file, making for quick geometry updates and data exchanges within CGS plus and Autodesk software solutions. LandXML and AutoCAD Civil 3D data exchange interfaces are available. Dynamic updates to all geometry changes or design parameters are supported within single or multiple drawings with separated layout/profile and cross sections data.



Supporting Large Projects

Aquaterra easily handles large projects with very long alignments and thousands of cross-sections within seconds. Projects are neither limited in size nor is the performance critically affected while working on large scale projects, including extra long and multiple alignments, profiles, and cross section views. Cross sections can provide a high level of details with on-demand synchronization options, great processing speed, and consistent data.



Intuitive user interfaces and workflows

User oriented ribbon layout and comprehensive dialogues enable fast learning for the first time users while toolbox and command line options provide faster design options for experienced users. Aquaterra time-saving UI design and simple to follow workflows help users to use their creativity without compromising engineering efficiency. Automated functions make designs time saving.



Supported language versions

Aquaterra is available in several languages. Customers are entitled to use any country specific version of the software in case of designing projects for the foreign countries. Currently supported language versions are:

- Croatian,
- English (International),
- German,
- Serbian,
- Slovenian.



Supported platforms

Aquaterra 2017 runs on top of 2017-2013 versions of AutoCAD Civil 3D, AutoCAD or AutoCAD Map 3D as well as BricsCAD V16-V13. Only 64-bit versions are supported!



Extend Aquaterra's functionality with point cloud data processing software - 3Dsurvey

3Dsurvey is a standalone software solution for point cloud data processing. Use any UAV with Lidar, a digital camera, DSLR, or a GoPro to capture images and process them in 3Dsurvey. Create orthophoto data or digital terrain models, calculate volumes, profiles, and even more.

Export digital terrain models to Aquaterra to create river projects based on detailed surface model, calculate material volumes, and export 3D river surface models from Aquaterra back to 3Dsurvey to create stunning aerial or drive-through visualizations.

3Dsurvey is available as a Aquaterra add-on (bundled) software solution.



About CGS plus and its software solutions

Founded in 1990, CGS plus is an innovative IT company, focused on civil engineering, transportation and environmental technologies. With its products Plateia (roadway design), Ferrovía (railway design), Aquaterra (river engineering works design), Autopath (vehicle swept path analysis) etc. CGS plus is among worldwide leading civil engineering software developers. CGS plus is also developing customized OEM CAD and BIM solutions for renowned software vendors. With its offices in Slovenia, Germany, and USA and with its wide reseller's network, it serves more than 8,000 customers in 33 countries.



Head Office Europe / Slovenia

CGS plus d.o.o.

Brnčičeva ulica 13
SI-1000 Ljubljana, Slovenia

Internet: www.cgsplus.com
email: info@cgsplus.com
Phone: +386 1 530 11 00

Office Germany

CGS Labs GmbH

Egerstraße 2
65205 Wiesbaden, Germany

Internet: www.cgs-labs.de
email: info.de@cgs-labs.com
Phone: +49 611 71678230

Office USA

CGS plus LLC

3426 NW 14th Ave
Camas, WA 98607, USA

Internet: <http://usa.cgsplus.com>
email: info.usa@cgsplus.com
Phone: (360) 210-5397

